

Technical Specifications

Materials	Steel Tubes and Cast Iron Radiator
Connections	½" flow and return.
Test pressure	13 Bar
Testing authority	EN442
Maximum operating pressure	10 Bar
Maximum working temperature	95 °C
Packaging	Bubble wrapped in cardboard box on a pallet

PLEASE NOTE: Systems using micro bore pipework must have adequate pressure and flow rates for the number and style of radiators on the system.

Terms & Conditions

All products must be inspected once removed from the packaging and The Radiator Company notified within 28 days of delivery of any scratches, blemishes or other damage. The Radiator Company will then replace the radiator.

Imperfect radiators should therefore not be fitted and The Radiator Company will not accept responsibility for replacement of scratched or damaged radiators once they have been fitted. This includes any consequential loss or cost of fitting.

If The Radiator Company are not notified within 28 days of the date on the signed delivery note then it will be deemed that The Radiator Company have fully complied with its obligations and claims will not be considered.

Failure to comply with any of the above may invalidate any claims. We recommend that after you check the product on delivery that it is stored in its packaging to prevent damage prior to installation. The Radiator Company cannot accept responsibility for items damaged after delivery.

Guarantees & Liabilities

As we are not the manufacturers of this product we will take all reasonable endeavours to make over to you the benefit of any warranty or guarantee given by the manufacturer, which is usually five years on most of our range. (Copies of specific guarantees for any of our products are available on request).

The guarantees in all cases are subject to the products being installed in accordance with British and or European standards as well as these fitting instructions. The guarantees in all cases are restricted to the free of charge replacement or repair of the failed product only. Our liability will under no circumstances extend beyond the repair or replacement of the product supplied by us. Claims for either labour in replacement or damage to property are not admissible. Any goods that are returned, in the event of a problem, will belong to The Radiator Company.

Fittings Instructions



Please read these instructions and terms and conditions carefully prior to installation. Failure to do so may invalidate the warranty

The Radiator Company
Units 13 - 14 Charlwoods Road
East Grinstead
West Sussex
RH19 2HU



Diagrams of Linton Towel Rail

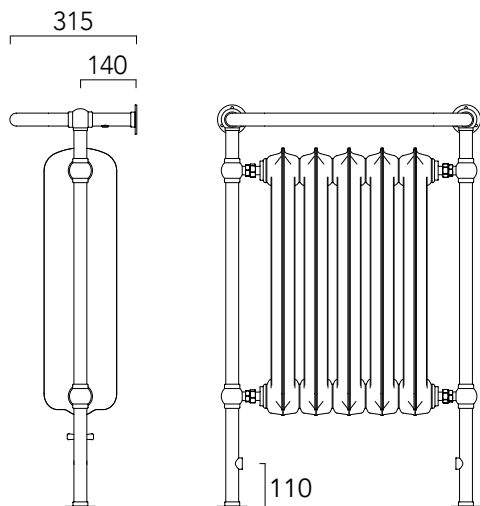

Pipe Centres

Tapping Centres =	width - 122mm (+/- 2mm)
Pipe centres left to right =	width - 122mm (+/- 2mm) + valves
Pipe centres from wall =	140mm
Maximum depth from wall =	315mm

1 Unpack & Inspect

The Radiator Company prides itself on selecting products from manufacturers who exercise tight quality control measures. We only select models with excellent standards of welding and brazing, as well as high quality finishes. All of our products are well packaged and should reach you in perfect condition. Just in case however, we offer a minimum 5-year no quibble guarantee for all radiators and towel rails.

The Radiator Company must be notified of any shortages or damage within 28 days of delivery. For further information please see terms and conditions on back page.



2 Contents

You should have:

- 1 Radiator

You will need:

- Tape measure
- Electric drill and bits
- Spirit level

3 Mark Bracket Positions

Place the radiator in the position desired, and mark through the holes where drilling is needed.

4 Fix Brackets

Using a suitable drill bit, screws and plugs, fix the brackets and level with a spirit level. Please see diagrams.



PLEASE NOTE :

It is essential that all brackets are level to ensure a vertical alignment for connecting the pipework.

5 Commission

Please Note:

In accordance with Part L1 2006 of the Building Regulations and BS7593:1992 code of practice for the treatment of hot water and central heating systems, we strongly recommend flushing the heating system post installation of new radiators and then adding the correct quantity and type of inhibitor for use with your radiator and system to prevent corrosion. Damage caused to systems not protected by a suitable inhibitor will not be covered by manufacturer's guarantee.