

## Technical Specifications

<b>Materials</b>	Steel.
<b>Connections</b>	½" flow and return.
<b>Test pressure</b>	10 Bar
<b>Testing authority</b>	EN442
<b>Maximum operating pressure</b>	8 Bar
<b>Maximum working temperature</b>	80°C
<b>Packaging</b>	Polystyrene protection within cardboard box.

## Terms & Conditions

All products must be inspected once removed from the packaging and The Radiator Company notified within 28 days of delivery of any scratches, blemishes or other damage. The Radiator Company will then replace the radiator.

Imperfect radiators should therefore not be fitted and The Radiator Company will not accept responsibility for replacement of scratched or damaged radiators once they have been fitted. This includes any consequential loss or cost of fitting.

If The Radiator Company are not notified within 28 days of the date on the signed delivery note then it will be deemed that The Radiator Company have fully complied with its obligations and claims will not be considered.

Failure to comply with any of the above may invalidate any claims.

We recommend that after you check the product on delivery that it is stored in its packaging to prevent damage prior to installation. The Radiator Company cannot accept responsibility for items damaged after delivery.

## Guarantees & Liabilities

As we are not the manufacturers of this product we will take all reasonable endeavours to make over to you the benefit of any warranty or guarantee given by the manufacturer, which is usually five years on most of our range. (Copies of specific guarantees for any of our products are available on request).

The guarantees in all cases are subject to the products being installed in accordance with British and or European standards as well as these fitting instructions. The guarantees in all cases are restricted to the free of charge replacement or repair of the failed product only. Our liability will under no circumstances extend beyond the repair or replacement of the product supplied by us. Claims for either labour in replacement or damage to property are not admissible. Any goods that are returned, in the event of a problem, will belong to The Radiator Company.



TRC 13mm, 25mm,  
Vision 13/25, Gullwing

## Fittings Instructions

### Includes new Aladdin Autovent fittings instructions

#### Automatic Radiator Bleed Valve

Matching  
blanking plug  
included if  
required  
for your  
radiator



Vertical tubular radiators create the perfect feature for any urban interior.

Please read these instructions and terms and conditions carefully prior to installation. Failure to do so may invalidate the warranty.

**The Radiator Company**  
TRC House  
Units 13 - 14 Charlwoods Road  
East Grinstead  
West Sussex  
RH19 2HU

If you have any questions please contact us on 01342 302250  
[www.theradiatorcompany.co.uk](http://www.theradiatorcompany.co.uk)

If you have any questions please contact us on 01342 302250  
[www.theradiatorcompany.co.uk](http://www.theradiatorcompany.co.uk)

## Diagrams of Tubular Vertical

### 13mm

TRC 13, Gullwing, Vision 13

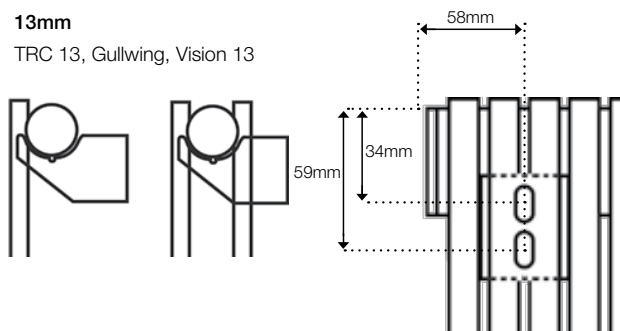

### 25mm

TRC 25, Vision 25

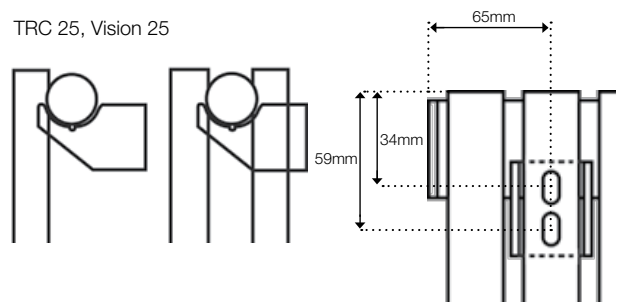

## Pipe Centres

Pipe centres left to right = width of radiator plus valves

Pipe centres from wall = 54mm

Depth from wall = TRC 13 = 80mm, Gullwing = 110mm,  
Vision 13 = 80mm  
TRC 25 = 94mm, Vision 25 = 94mm,

## 1 Unpack & Inspect

The Radiator Company prides itself on selecting products from manufacturers who exercise tight quality control measures. We only select models with excellent standards of welding and brazing, as well as high quality finishes. All of our products are well packaged and should reach you in perfect condition. Just in case however, we offer a minimum 5-year no quibble guarantee for all radiators and towel rails.

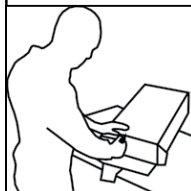

Please carefully unpack and inspect this radiator and all fittings. The Radiator Company must be notified of any shortages or damage within 28 days of delivery. For further information please see terms and conditions on back page.

## 2 Contents

You should have:

- 1 Radiator
- 4 Wall brackets
- 8 Plastic sleeves
- 1 Aladdin Autovent HV30 Valve
- 1 Aladdin Blanking Plug, if your radiator requires a plug
- 1 Hex screw
- 1 Allen key
- 2 Decorative O ring

You will need:

- Tape measure
- Electric drill and bits
- Spirit level

## 3 Mark Bracket Positions

### TRC 13, Vision 13

The fixing positions for the two top brackets are measured down 34mm and 59mm and typically spaced one tube in from either end at width - 58mm (Please see diagram).

### TRC 25, Vision 25

The fixing positions for the two top brackets are measured down 34mm and 59mm and typically spaced one tube in from either end at width - 65mm (Please see diagram).

## 4 Fix Brackets

Using a suitable drill bit, screws and plugs, fix the brackets and level with a spirit level. Please see diagrams.

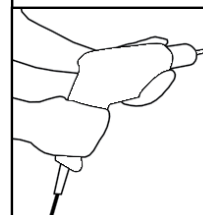

### PLEASE NOTE :

It is essential that all brackets are level to ensure a vertical alignment for connecting the pipework.

## 5 Identify Diverter Position

The factory fitted diverter can be identified by a 'diagramma' sticker found on the underside of one collector. The radiator must be hung with the diverter at the bottom. If this sticker is missing simply look into both collectors, one will have a clear water way and one will have a deliberate blockage, this deliberate blockage is the diverter.

## 6 Hang Radiator & Commission

With the brackets firmly fixed, level, the plastic sleeves fitted and the diverter at the bottom, the radiator is lowered directly onto the brackets.

## 7 Installation of Autovent

- The valve will operate faster if fitted to the hotter, flow side of the radiator.
- To fit the round airvent, first insert the airvent until hand tight then use hex key supplied and place in the hole on the side of the vent to tighten.
- Place the decorative O ring over the vent and tighten the small grub screw with the hex key supplied; Please note the small grub screw is not designed to fit into the hole on the side of the airvent, the grub screw should grip the side of the vent to enable the ring to fit flush.
- Although the o-ring provides sufficient seal and no tape or sealant is required, a small amount of PTFE tape must be used if preferred.
- When priming the radiator, air will bleed automatically until water reaches the valve when it will shut automatically.

### After the first fill

- Dependant upon system temperature and pressure, it may take up to 48 hours for the valve to operate after the first fill.
- To drain down the radiator, once there is no internal pressure in the system, use a spanner to loosen the valve half a turn or so to allow air to enter the system.
- To refill after draining, either wait up to 6 hours for the valve to reset to automatic operation, or vent manually using a spanner.
- The valves have a guaranteed 3 year life after which, if the radiator collects air, replacements can be purchased from The Radiator Company.