

## Technical Specifications

<b>Materials</b>	Steel.
<b>Connections</b>	½" flow and return.
<b>Test pressure</b>	5 Bar
<b>Testing authority</b>	Politecnico di Milano
<b>Maximum operating pressure</b>	3.3 Bar
<b>Maximum working temperature</b>	95°C
<b>Packaging</b>	Wrapped in polythene in a wooden box.

## Terms & Conditions

All products must be inspected once removed from the packaging and The Radiator Company notified within 28 days of delivery of any scratches, blemishes or other damage. The Radiator Company will then replace the radiator.

Imperfect radiators should therefore not be fitted and The Radiator Company will not accept responsibility for replacement of scratched or damaged radiators once they have been fitted. This includes any consequential loss or cost of fitting.

If The Radiator Company are not notified within 28 days of the date on the signed delivery note then it will be deemed that The Radiator Company have fully complied with its obligations and claims will not be considered.

Failure to comply with any of the above may invalidate any claims.

We recommend that after you check the product on delivery that it is stored in its packaging to prevent damage prior to installation. The Radiator Company cannot accept responsibility for items damaged after delivery.

## Guarantees & Liabilities

As we are not the manufacturers of this product we will take all reasonable endeavours to make over to you the benefit of any warranty or guarantee given by the manufacturer, which is usually five years on most of our range. (Copies of specific guarantees for any of our products are available on request).

The guarantees in all cases are subject to the products being installed in accordance with British and or European standards as well as these fitting instructions. The guarantees in all cases are restricted to the free of charge replacement or repair of the failed product only. Our liability will under no circumstances extend beyond the repair or replacement of the product supplied by us. Claims for either labour in replacement or damage to property are not admissible. Any goods that are returned, in the event of a problem, will belong to The Radiator Company.

## Fittings Instructions

### Includes new Aladdin Autovent fittings instructions

#### Automatic Radiator Bleed Valve



Matching  
blanking plug  
included if  
required for  
your radiator



A modern technological masterpiece, the Metacrylic combines an efficient steel tube radiator with striking acrylic overlay.

Please read these instructions and terms and conditions carefully prior to installation. Failure to do so may invalidate the warranty.

**The Radiator Company**  
TRC House  
Units 13 - 14 Charlwoods Road  
East Grinstead  
West Sussex  
RH19 2HU

## Diagrams of Metacrylic

Metacrylic

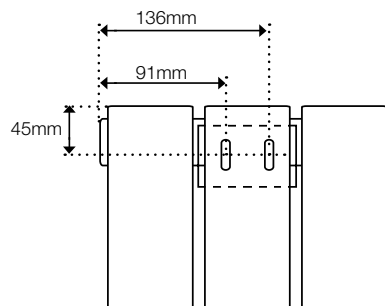

## Pipe Centres

Pipe centres left to right	=	width plus valves
Pipe centres from wall	=	55mm
Depth from wall	=	150mm

## 1 Unpack & Inspect

The Radiator Company prides itself on selecting products from manufacturers who exercise tight quality control measures. We only select models with excellent standards of welding and brazing, as well as high quality finishes. All of our products are well packaged and should reach you in perfect condition. Just in case however, we offer a minimum 5-year no quibble guarantee for all radiators and towel rails.

Please carefully unpack and inspect this radiator and all fittings. The Radiator Company must be notified of any shortages or damage within 28 days of delivery. For further information please see terms and conditions on back page.

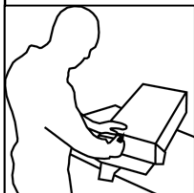

Please Note: Care must be taken when handling this radiator, do not use the acrylic panel as a lifting point and or to hold the radiators weight, as this may cause damage.

## 2 Contents

You should have:

- 1 Radiator
- 4 Wall brackets
- 8 Wall Plugs
- 8 Screws
- 8 Plastic sleeves
- 1 Aladdin Autovent HV30 Valve
- 1 Aladdin Blanking Plug, if your radiator requires a plug
- 1 Diverter

You will need:

- Tape measure
- Electric drill and bits
- Spirit level
- 10mm long reach allen key or 10mm hex bit plus long reach driver. (only required if fitting diverter - see step 6).

## 3 Mark Bracket Positions

The two fixing positions for the two top brackets are measured at 91mm and 136mm in from either end of the top collector and measured down 45mm (please see diagram opposite).

In order to accurately mark the bottom bracket fixing positions we recommend you mark, fix and level the two top brackets first. Then hang the radiator, ensuring it is vertically level and manually hold the bottom brackets in position while marking.

Care should be taken when handling the Metacrylic radiator to avoid damaging the acrylic panel.

## 4 Fix Brackets

Using a suitable drill bit, screws and plugs, fix the brackets with the screw positioned centrally in the bracket slot. By fixing in the centre you will be able to raise and lower the bracket to ensure a vertical alignment

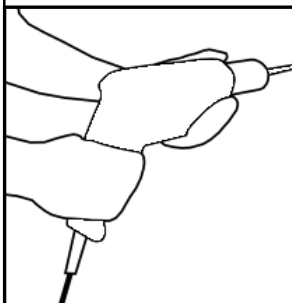

### PLEASE NOTE :

It is essential that all brackets are level to ensure a vertical alignment for connecting the pipework.

## 5 Hang Radiator

With the brackets firmly fixed and level and the plastic sleeves fitted, the radiator is lowered directly onto the brackets.

## 6 Fitting Diverter & Commission

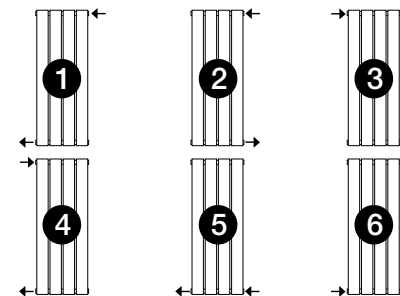

For connection options 1, 2, 3 & 4 the radiator can be commissioned as supplied without the need for the diverter to be installed.

For connection options 5 or 6 you will need to insert the diverter into the collector. The diverter is the threaded nut with a 10mm hex slot contained in the fittings pack. The diverter position is indicated by a coloured label (please see diagram below).

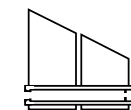

Open collector as supplied

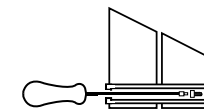

Insert diverter to close collector

## 7 Installation of Autovent

- The valve will operate faster if fitted to the hotter, flow side of the radiator.
- Use a suitable spanner to fit, but do not over-tighten.
- Although the o-ring provides sufficient seal and no tape or sealant is required, a small amount of PTFE tape must be used if preferred.
- When priming the radiator, air will bleed automatically until water reaches the valve when it will shut automatically.

### After the first fill

- Dependant upon system temperature and pressure, it may take up to 48 hours for the valve to operate after the first fill.
- To drain down the radiator, once there is no internal pressure in the system, use a spanner to loosen the valve half a turn or so to allow air to enter the system.
- To refill after draining, either wait up to 6 hours for the valve to reset to automatic operation, or vent manually using a spanner.
- The valves have a guaranteed 3 year life after which, if the radiator collects air, replacements can be purchased from The Radiator Company.